



DIRECTIONAL CONTROLS

MANUALLY OPERATED DIRECTIONAL VALVE



SPECIFICATIONS

MODEL CODE	MAX. FLOW LPM (GPM)	MAX. PRESSURE KGF/CM 2(PSI)
HD-G02-***-10	63(16.6)	210 (3000)
HD-T03-*C*-10	100 (25)	210 (3000)
HD-T03-2D*-10	100 (25)	210 (3000)
HD-T03-2B*-10	100 (25)	210 (3000)
HD-T06-*C*-10	300 (80)/ 200* (52*)	210 (3000)
HD-T06-2D*-10	300 (80)	210 (3000)
HD-T06-2B*-10	200 (52)	210 (3000)
HD-T10-*C*-10	500 (132) / 315* (83*)	210 (3000)
HD-T10-2D*-10	500 (132)	210 (3000)
HD-T10-2B*-10	315 (83)	210 (3000)

*** IS THE RATING FOR 3C3, 3C5, 3C6**

HOW TO ORDER

HD - G02 - 2 B * - 10 - N

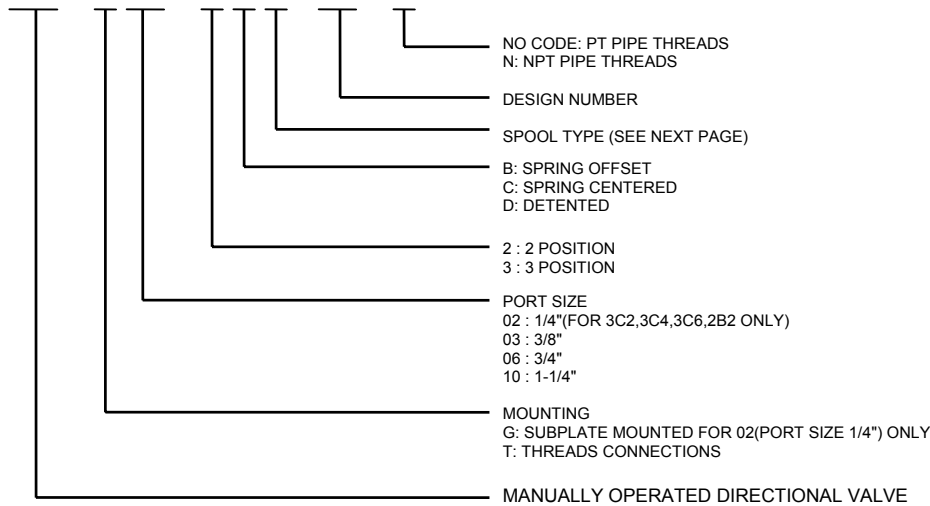

DIRECTIONAL CONTROLS

MANUALLY OPERATED DIRECTIONAL VALVE

SPOOL TYPES

APPLICATION	TYPE	GRAPHIC SYMBOLS
THREE POSITION SPRING CENTERED	C2	
	C3	
	C4	
	C40	
	C5	
	C6	
	C60	
	C7	
	C8	
TWO POSITION DETENT	D2	
	D3	
TWO POSITION SPRING OFFSET	B2	
	B3	
	B20	
TWO POSITION SPRING OFFSET	B2S	
	B3S	
	B20S	



HD-T03 PRESSURE DROP CURVES

TEST FLUID VISCOSITY : 35 cSt (175 SSU)
TEST TEMPERATURE: 50°C(122°F)

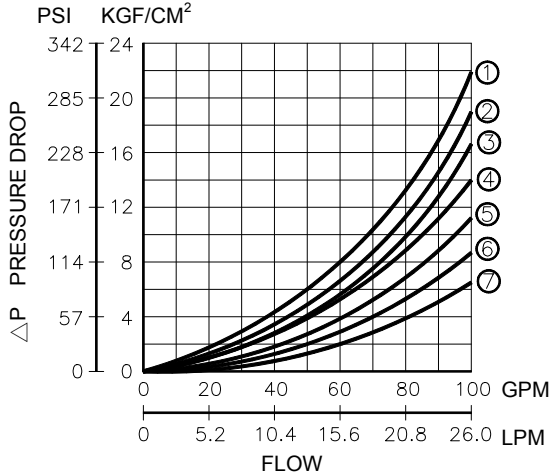

HD-T03 PERFORMANCE CHART

SPOOL TYPE	PRESSURE DROP LINE NUMBER				
	P→A	B→T	P→B	A→T	P→T
C2	4	5	4	5	-
C3	6	6	6	6	6
C4	4	7	4	7	-
C40	4	5	4	5	-
C5	6	5	4	6	2
C6	5	5	5	5	1
C60	5	5	5	5	1

HD-T06 PRESSURE DROP CURVES

TEST FLUID VISCOSITY : 35 cSt (175 SSU)
TEST TEMPERATURE: 50°C(122°F)

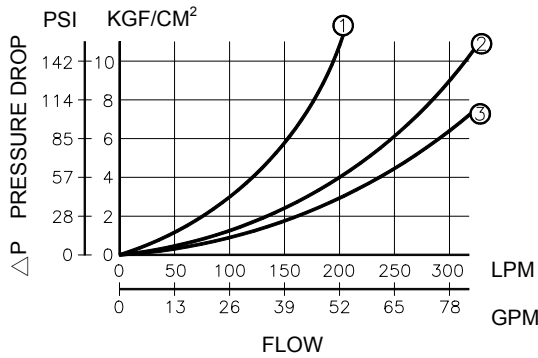

HD-T06 PERFORMANCE CHART

SPOOL TYPE	PRESSURE DROP LINE NUMBER				
	P→A	B→T	P→B	A→T	P→T
C2	2	2	2	2	-
C3	3	2	3	2	2
C4	2	3	2	2	-
C40	2	2	2	2	-
C5	3	2	2	2	-
C6	3	2	3	2	1
C60	3	2	3	2	1

HD-T10 PRESSURE DROP CURVES

TEST FLUID VISCOSITY : 35 cSt (175 SSU)
TEST TEMPERATURE: 50°C(122°F)

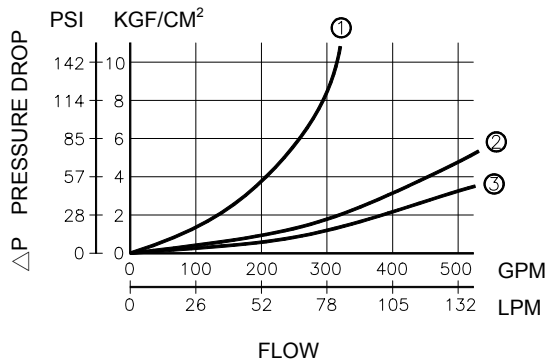

HD-T10 PERFORMANCE CHART

SPOOL TYPE	PRESSURE DROP LINE NUMBER				
	P→A	B→T	P→B	A→T	P→T
C2	3	2	3	2	-
C3	3	2	3	2	2
C4	3	3	3	2	-
C40	3	2	3	2	-
C5	3	2	3	2	-
C6	3	3	3	3	1
C60	3	3	3	3	1

