

PRESSURE CONTROLS

SOLENOID CONTROLLED PILOT OPERATED RELIEF VALVE

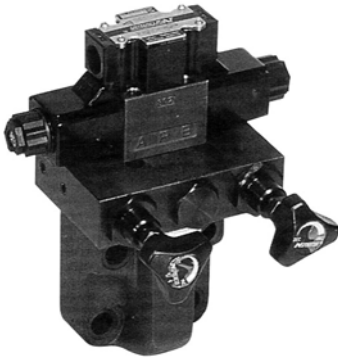

FEATURES

- The series of SRF-T/G valves are the combination of solenoid operated directional control valve and RF-G relief valve in one integrated body to provide a wide variety of pressure control possibilities. Solenoid control permits convenient electrical selection of system pressures. Selection for pressure or vent, either of two pressures, or two pressures and vent, or one of three pressures can be achieved by proper selection of the valves listed below.

SPECIFICATIONS

MODEL	MAX. PRESSURE KGF/CM ² (PSI)	RATED FLOW LPM(GPM)	PRESSURE ADJ. RANGE KGF/CM ² (PSI)
SRF-G04	250 (3500)	100(26.4)	1: 7-70(100-1000)
SRF-G/T06		200(52.8)	2: 35-140(500-2000)
SRF-G10		400(105.6)	3: 70-250(1000-3550)

HOW TO ORDER

SRF-G06-1PN-1-A220-10-30-A1-N

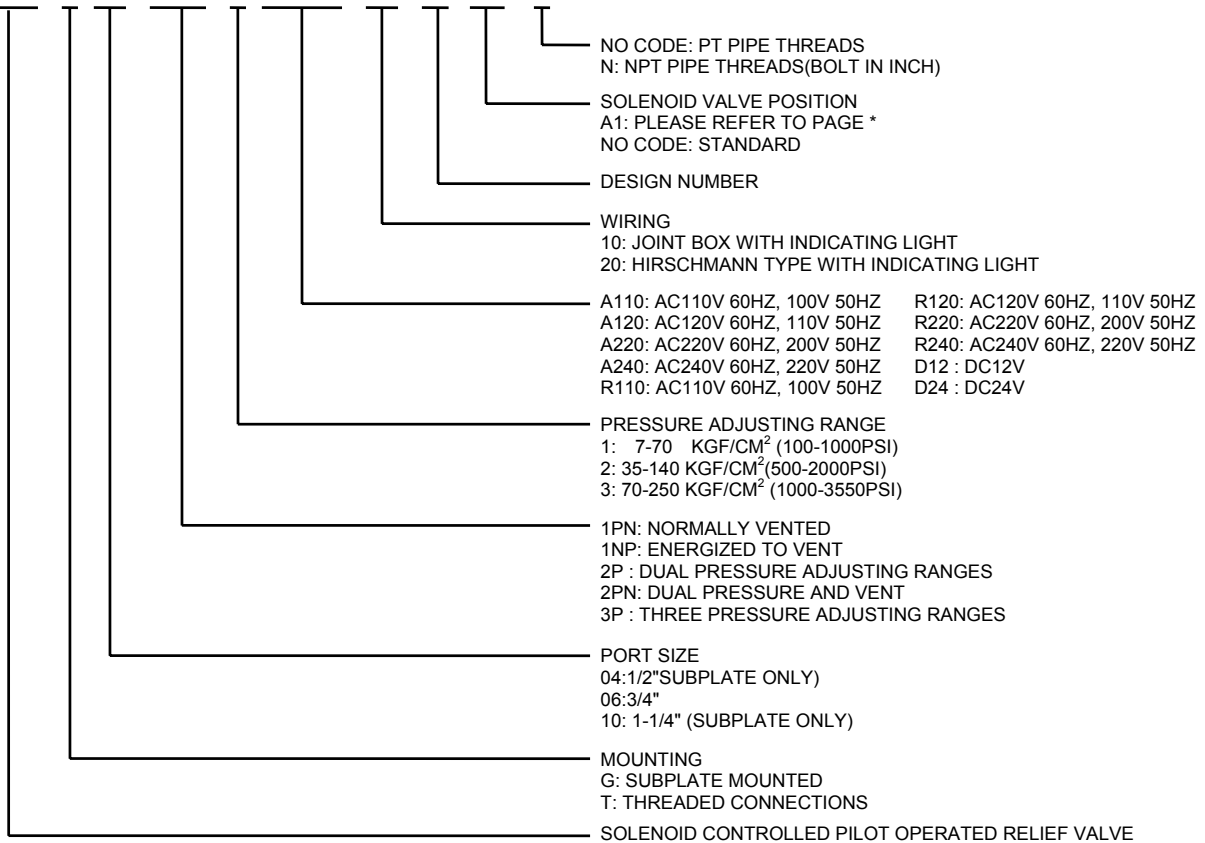

SYMBOLS & FUNCTION TABLES

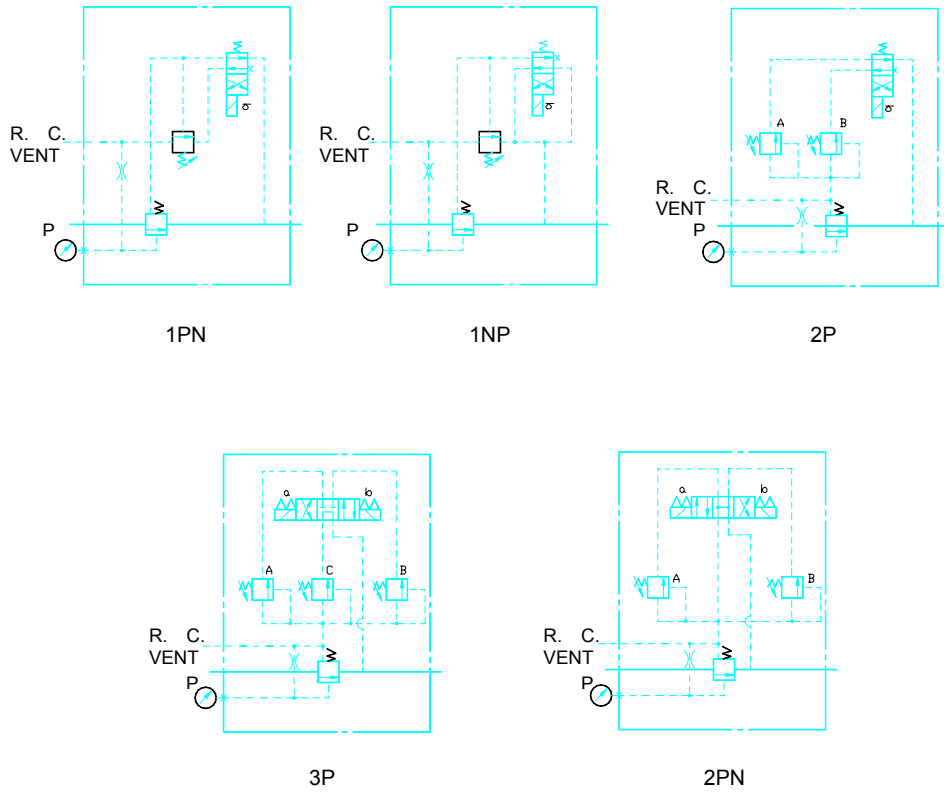

MODEL	INPUT		OUTPUT
	SOL b	SOL a	
1PN	OFF	NONE	VENTED
	ON		ADJUSTABLE PRESSURE
1NP		OFF	ADJUSTABLE PRESSURE
	NONE	ON	VENTED
2P	OFF	NONE	ADJUSTABLE PRESSURE AT A
	ON		ADJUSTABLE PRESSURE AT B
2PN	OFF	OFF	VENTED
	ON	OFF	ADJUSTABLE PRESSURE AT A
	OFF	ON	ADJUSTABLE PRESSURE AT B
3P	OFF	OFF	ADJUSTABLE PRESSURE AT C
	ON	OFF	ADJUSTABLE PRESSURE AT A
	OFF	ON	ADJUSTABLE PRESSURE AT B

PRESSURE CONTROLS

SOLENOID CONTROLLED PILOT OPERATED RELIEF VALVE

INSTALLATION DIMENSIONS

UNIT : mm(inch)

SRF-G*-1PN/1NP

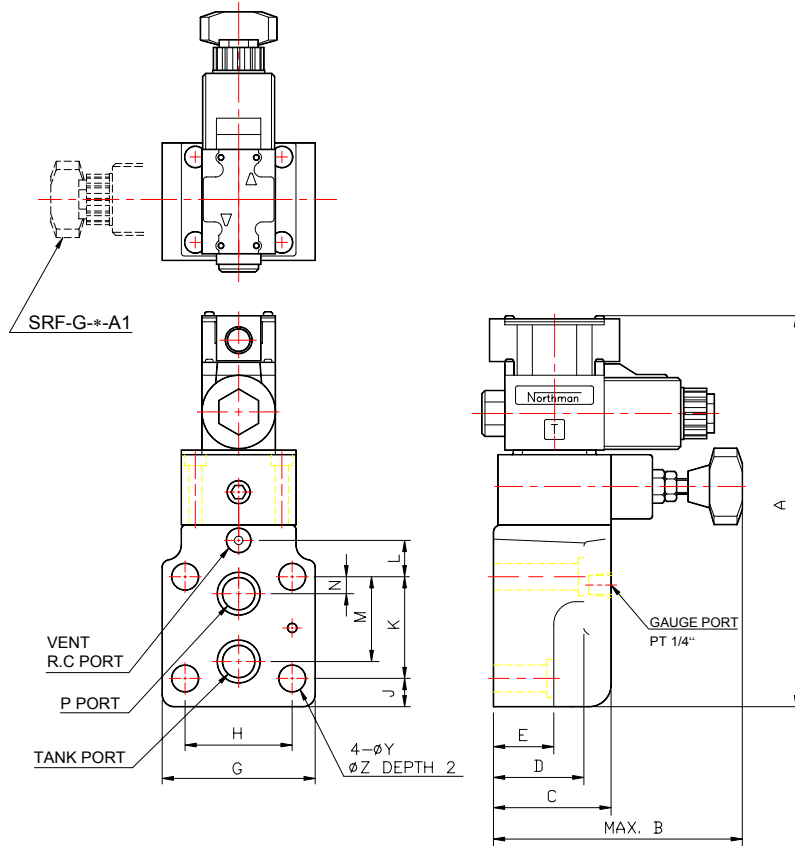

MODEL	A	B	C	D	E	G	H	J	K
SRF-G04 SERIES	228.5 (9.00)	175 (6.89)	78 (3.07)	78 (3.07)	57 (0.67)	82 (3.23)	53.8 (2.12)	21.5 (0.89)	53.8 (2.12)
SRF-G06 SERIES	254 (9.61)	175 (6.85)	78 (3.07)	60 (2.36)	40 (0.67)	102 (4.09)	70 (2.76)	19 (0.67)	66.7 (2.63)
SRF-G10 SERIES	281 (11.06)	184 (7.24)	87.5 (3.45)	67 (2.64)	47 (0.71)	124 (4.88)	82.6 (3.25)	20 (0.71)	88.9 (3.5)

MODEL	L	M	N	Y	Z	WEIGHT	SUBPLATE TYPE
SRF-G04 SERIES	0 (0)	47.5 (2.13)	22 (0.87)	13.5 (0.53)	21 (0.83)	7.5 KGS (16.5 LBS)	MF-04
SRF-G06 SERIES	23.8 (0.94)	55.5 (2.19)	11 (0.43)	17.5 (0.69)	26 (1.02)	8.0 KGS (17.6 LBS)	MF-06
SRF-G10 SERIES	31.8 (1.25)	76.2 (3.00)	12.7 (0.50)	22 (0.85)	32 (1.26)	25 KGS (55.1 LBS)	MF-10



INSTALLATION DIMENSIONS

UNIT : mm(inch)

SRF-G06/G10-2P

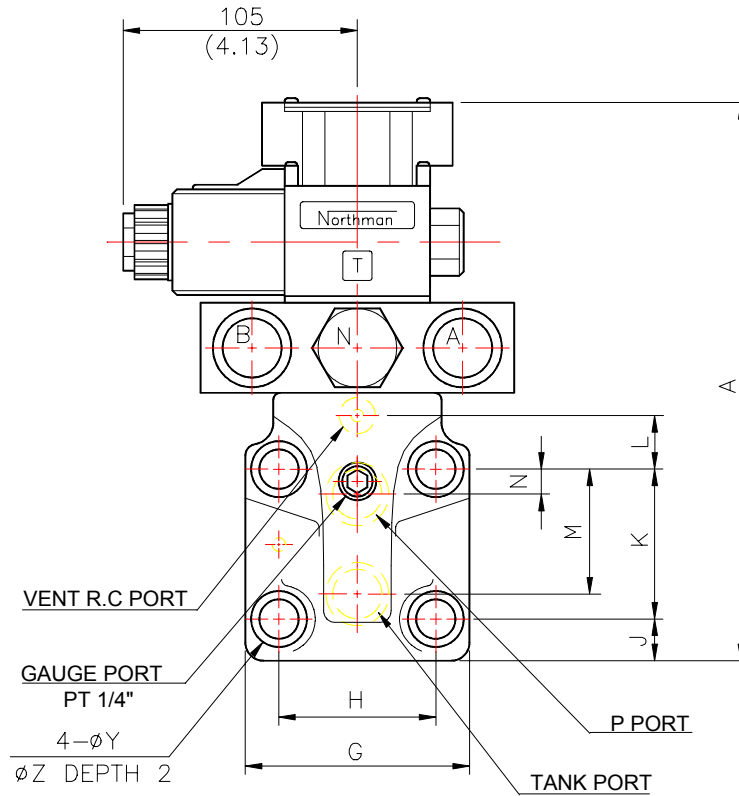

MODEL	A	G	H	J	K	L	M	N	Y	Z	WEIGHT	SUBPLATE TYPE
SRF-G06 SERIES	244 (9.61)	104 (4.09)	70 (2.76)	16.9 (0.67)	66.7 (2.63)	23.8 (0.94)	55.5 (2.19)	11 (0.43)	17.5 (0.69)	26 (1.02)	10 KGS (22.0LBS)	MF-06
SRF-G10 SERIES	281 (11.06)	124 (4.88)	82.6 (3.25)	18 (0.71)	88.9 (3.5)	31.8 (1.25)	76.2 (3.00)	12.7 (0.50)	21.5 (0.85)	32 (1.26)	27 KGS (59.5LBS)	MF-10



INSTALLATION DIMENSIONS

UNIT : mm(inch)

SRF-T06-1PN/1NP

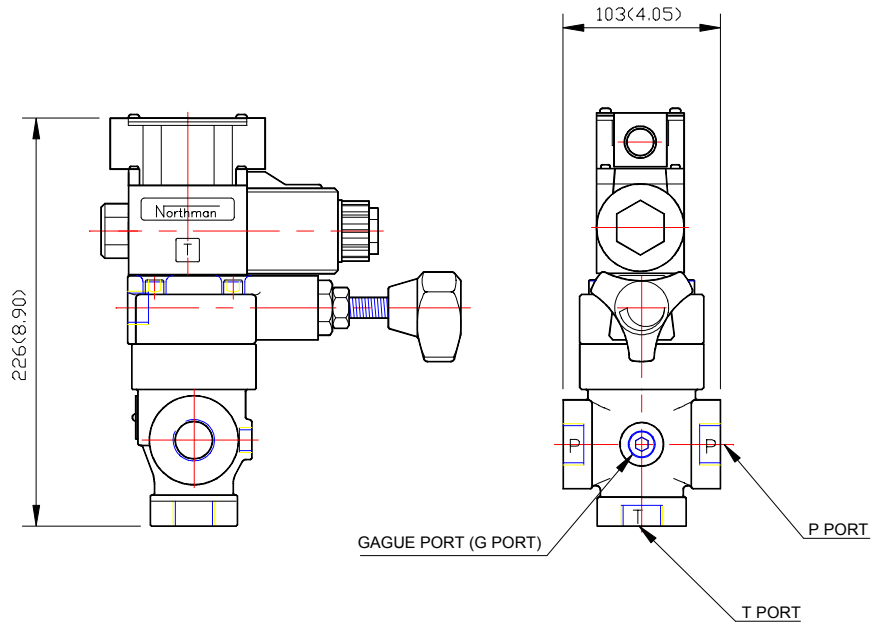

SRF-T06-2P/2PN/3P

